

THIS DRAWING IS UNPUBLISHED. RELEASED FOR PUBLICATION
 © COPYRIGHT BY TYCO ELECTRONICS CORPORATION. ALL INTERNATIONAL RIGHTS RESERVED.

LOC	DIST	REVISIONS			
P	LTR	DESCRIPTION	DATE	DWN	APVD
G	02	K1	REVISED PER ECR-08-013582	09JUN08	HMR TM

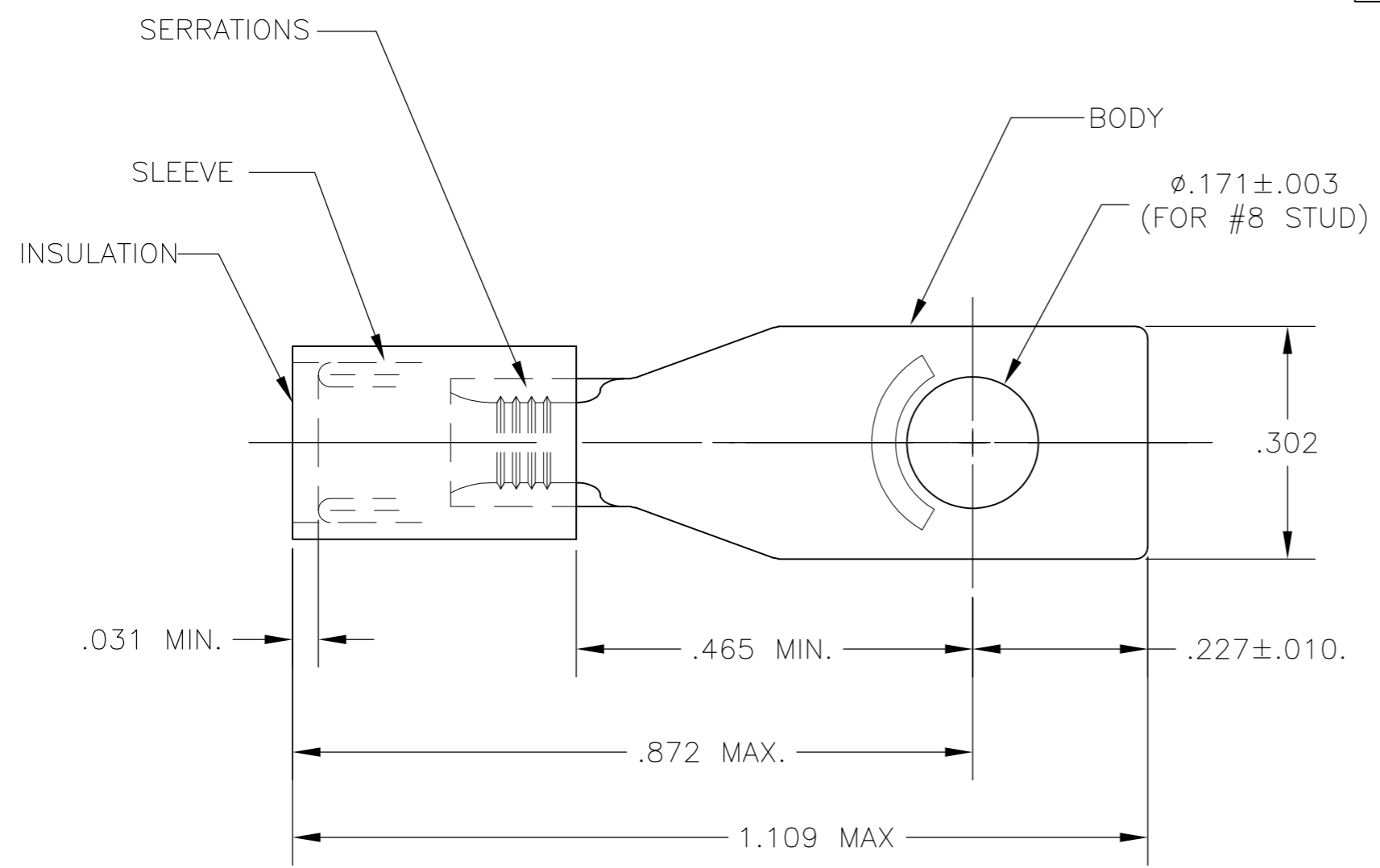

- 1 SUPERSEDED BY 327944
- 2 TONGUE MATERIAL THK=.031±.002 FOR .105 TO .140 WIRE INS. DIA
- 3 MARKING 22-18 FOR MILITARY COMMERCIAL RANGE 22-16

QTY	DESCRIPTION	PART NO	MATERIAL & FINISH
100	LOOSE PC. BOX	8-327944-1	INSULATION SLEEVE, BODY: SAME AS 327944
OBSOLETE	1 2-327944-1 ON TAPE	2-327944-3	INSULATION: NYLON(MIL-M-20693) TYPE I COLOUR: RED BODY&SLEEVE: COPPER (QQ-C-576) TIN PL (MIL-T-10727)
	1 WIRE TERMINAL	2-327944-1	
1	327944 ON TAPE	2-327944-2	INSULATION: NYLON COLOUR: RED SLEEVE: COPPER (QQ-C-576) BODY: COPPER (QQ-C-576) TIN PL (MIL-T-10727)
	1 WIRE TERMINAL	327944	

THIS DRAWING IS A CONTROLLED DOCUMENT.		DWN RAGHAVENDRA HM 09JUN08	Tyco Electronics Corporation Harrisburg, PA 17105-3608	
DIMENSIONS: INCHES	TOLERANCES UNLESS OTHERWISE SPECIFIED:	CHK T MICHIELUTTI 09JUN08	NAME	
	0 PLC ± -	APVD T MICHIELUTTI 09JUN08	WIRE TERMINAL, PIDG, RECTANGULAR TONGUE WIRE SIZE : 22-16	
	1 PLC ± -	PRODUCT SPEC	SIZE CAGE CODE DRAWING NO RESTRICTED TO	
MATERIAL	FINISH	APPLICATION SPEC	A3 00779 C-327944	
SEE TABLE	SEE TABLE	WEIGHT	CUSTOMER DRAWING SCALE 5:1 SHEET 1 OF 1 REV K1	